

Experiment 1: Amplifier Characterization

Spring 2022

Objective: The objective of this experiment is to develop methods for characterizing key properties of operational amplifiers

1 Introduction

Amplifiers are one of the major components and building block used in analog and mixed-signal circuits. For printed circuit board designs, the designer usually uses discrete operational amplifiers (op amps) that have the ability to drive relatively large capacitive loads which may be a combination of parasitic capacitances from the board traces in addition to any required capacitive load. These discrete op amps are some times called "catalog op amps" and are usually harder to design than embedded op amps that are used as components in larger on-chip systems. The design of catalog op amps is generally more challenging because of the requirement that they be useful in a wide variety of applications that may have varied performance requirements. Invariably this requirement for use in a wide variety of applications requires meeting rather stringent performance requirements on characterization parameters such as dc gain, gain-bandwidth product (GB), slew rate, offset voltage, power consumption, power supply rejection ratio, common mode rejection ratio, signal swing, etc.

In this experiment, several performance parameters, often termed specifications, that are widely used to characterize an op amp will be investigated. These specifications are the offset voltage, V_{os} , the open loop voltage gain, A_o , the slew rate, SR , and the gain bandwidth product, GB . These specifications will be measured for both the commercial TL082 operational amplifier and the single-ended push-pull amplifier shown in Fig. 1. A standard CMOS inverter such as a C4004 or a MOS transistor array, the CD 4007, can be used to build the push-pull amplifier.

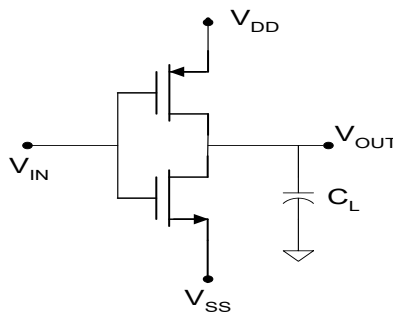

Fig. 1 Single-ended Push-Pull Amplifier

Some operational amplifiers are designed to operate with a fixed supply voltage and others are designed to operate over a wide range of supply voltages. The performance specifications, however, may change somewhat with supply voltage for amplifiers designed to operate over a large supply range.

Stability and compensation are also key issues that must be addressed when designing and using operational amplifiers. Although it is premature to discuss these concepts in detail at this point in the course, issues surrounding stability and compensation will be investigated experimentally in this experiment as well.

2 Performance Parameter Measurements

2.1 Open Loop Gain, A_0

Most operational amplifiers are designed to have a single-pole lowpass response that can be expressed as

$$A(s) = \frac{A_0}{s + p} \quad (1)$$

where A_0 is the dc gain of the operational amplifier and where $-p$ is the location of the dominant pole. The pole is in the left half plane and is thus negative (i.e. p in (1) is positive). $A(s)$ is often referred to as the open-loop gain of the op amp. In most internally compensated general purpose op amps, the magnitude of the pole p is in the range of 10 rad/sec. It can be readily shown that the 3dB bandwidth of the open loop gain is p . Thus, by definition, the gain-bandwidth product, GB , is given by the expression

$$GB = A_0 p \quad (2)$$

Measure the open loop gain, A_0 , of the TL082 operational amplifier and of the push-pull amplifier shown in Fig. 1. Make a comparison of these measured results with those given in the datasheets for the parts (make this comparison at the operating conditions specified in the datasheet).

This is a challenging measurement to make for any high gain operational amplifier because when the gain of the operational amplifier is large, the offset voltage of the operational amplifier is also amplified, and this amplification of the offset voltage tends to drive the amplifier into saturation if a direct open-loop measurement approach is followed.

If the output impedance of the op amp is small, the challenges associated with measuring the dc voltage gain can be reduced if the op amp is embedded in a feedback amplifier such as that shown in Fig. 2.

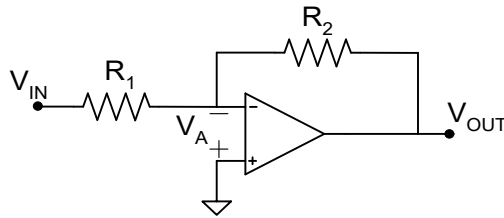

Figure 2: Feedback Configuration

In the feedback configuration, if the input offset voltage is neglected, the dc output voltage relates to the differential input voltage, V_A , of the op amp by the relationship

$$V_{OUT} = A_0 V_A \quad (3)$$

for any dc input. Thus, A_0 could be obtained by measuring V_{OUT} and V_A and taking the ratio. But if an input offset voltage is present, the output voltage given in (3) will include a component that is due to the input offset voltage so using (3) to obtain A_0 will give erroneous results.

Since the input offset voltage is a dc quantity, the effects of the offset voltage can be mitigated if a sinusoidal excitation or a square wave excitation is used for the input. By measuring the sinusoidal signals V_{OUT} and V_A , the gain can be determined from (3). However, if the gain A_0 is very large, the voltage V_A will be very small. To make the measurement of V_A practical, you will likely need to build another high gain amplifier with a second opamp to amplify the signal by a known amount. A gain of somewhere around 1000 is often a reasonable gain to set for this auxiliary amplifier. With this measurement approach, it is important that the frequency of the input be low enough so that it is well below the 3dB band edge of the operational amplifier itself. Check with the datasheet of the op amp to determine how low in frequency this input signal must be.

The measurement of the open loop gain of the single-ended amplifier of Fig. 1 is less challenging since the gain is somewhat smaller. Devise a method for measuring the open loop small signal voltage gain of this circuit and use it to measure the voltage gain at a quiescent output voltage of $V_{OUTQ} = (V_{DD} + V_{SS})/2$. Reasonable values for V_{DD} and V_{SS} might be +3V and -3V respectively. Regardless of what method you use to measure A_0 , it is critical that the output not be saturated during these measurements.

2.2 Slew Rate, SR

The slew rate of an amplifier is defined to be the maximum rate of change of the output voltage. This slew rate could correspond to the maximum rate of change of the operational amplifier output on negative going output transitions or the maximum rate of change of the operational amplifier output on positive going output transitions. In most amplifiers, the slew rate is nearly independent of the magnitude or direction of the output excursion. For some operational amplifiers, the positive going slew rate and the negative going slew rate are specified separately though this would be an uncommon operational amplifier.

Measure the slew rate of the TL082 op amp. Compare these measurement results with those given in the datasheet.

The simple buffer amplifier shown in Figure 3 is one of many circuits that is useful for measuring the slew rate of an op amp.

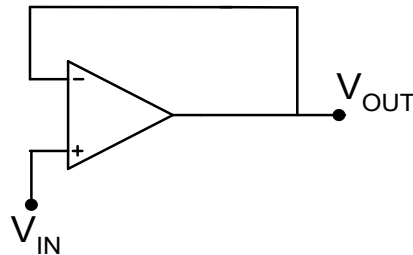

Fig. 3 Buffer Amplifier for SR Measurement

To measure the SR, a sinusoidal or a square wave input can be used. If a square wave excitation is used, the slope of the output waveform will be the SR. If a sinusoidal input is used, the input frequency and amplitude can be increased until the slope of the output is constant around the zero crossings or, in the more extreme case, until the output becomes a triangular waveform. The slope of this output waveform will be the SR.

2.3 Gain Bandwidth Product GB

Measure the gain-bandwidth product **GB** of the TL082 operational amplifier when loaded with a capacitor that is 10% of the maximum specified load for the device. Compare with that given in the datasheet. Measure the **GB** of the simple push-pull inverter when loaded with a 50pF load. (Sometimes the datasheet does not give the maximum capacitive load. If a maximum value is not given, do the measurement with the capacitive load given in the measurement section of the datasheet)

The units for the **GB** of an op amp can be expressed in either radians/sec or Hz. The units for ω in (1) are radians/sec but even ω is often given in Hz. Unfortunately the same symbol is often used for both ω and **GB** irrespective of whether they are expressed in radians/sec or Hz so be careful to not let this notational issue cause any problems.

If an electrolytic capacitor is used for the load on the op amp, it is critical that it be biased with the correct polarity. By definition, the **GB** of an op amp is the product of the dc voltage gain and the 3dB bandwidth as indicated in (2). Although the term **GB** can be defined for any amplifier, it is generally of most interest for amplifiers that have an open loop gain that can be modeled with a single-pole as given in (1). Most commercial op amps and most integrated op amps will be designed to have this single-pole gain characteristic. Verify from the datasheet of the TL082 that this component can be modeled as a single-pole amplifier.

As was observed previously, the dc voltage gain of a high gain operational amplifier is challenging to accurately measure. The 3dB bandwidth is even more difficult to measure. For these reasons, the **GB** of an op amp is almost never measured directly by measuring A_0 and the 3dB bandwidth and then taking the product of these two terms to obtain **GB**.

There is, however, an easy way to measure the GB of the operational amplifier without ever measuring either the dc gain or the 3dB bandwidth. A routine calculation shows that if the operational amplifier can be modeled as a single-pole amplifier, then the 3dB bandwidth of the feedback amplifier of Figure 2 relates to the magnitude of the feedback gain K and the GB of the op amp by the equation

$$GB = (1+K)f_{3dB} \quad (4)$$

where $K = \frac{R_2}{R_1}$. Derive the equation (4) for the GB assuming the single-pole model of

(1) accurately characterizes the op amp. Thus, measuring the closed-loop 3dB bandwidth and multiplying by $1 + K$ will give the GB of the op amp. In making this measurement, be sure the frequency and signal magnitudes are low enough so that there is no slewing at the output of the op amp.

2.4 Offset Voltage, V_{OS}

Measure the input-referred offset voltage for four different TL082 operational amplifiers and comment on how these offset voltages compare.

The input offset voltage is difficult to measure with an open loop configuration but can be readily and very accurately measured from characteristics of a feedback circuit. The basic idea here is to consider a circuit that is adversely affected by the offset voltage of the op amp and then use this circuit to measure or infer what the offset voltage must be. If the input voltage of the feedback amplifier of Fig. 1 is set to 0V, as shown in Fig. 4a, the output voltage is ideally zero.

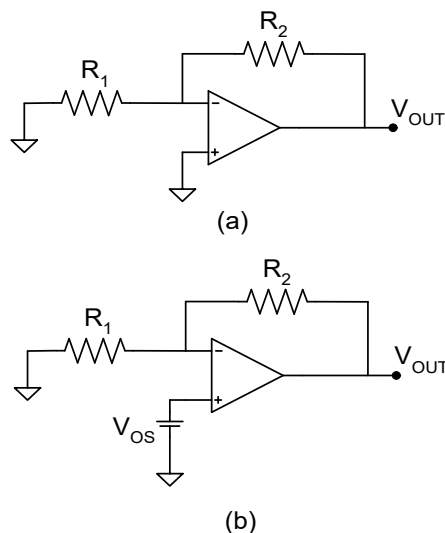

Fig. 4 Simple Feedback Amplifier for Measuring Offset Voltage

However, due to the input offset voltage, the output voltage will not be zero and if the gain of the feedback amplifier is large, a large dc voltage will appear on the output for most op amps even when the input voltage is zero. The offset voltage of an op amp is a random variable and can take on either positive or negative values. It will also vary from device to device. The designer goes to considerable effort when designing an op amp to make the offset voltage is small but inherent process variations from device to device will make it impossible to eliminate the offset voltage. The offset voltage can be modeled with a single dc voltage source in series with an input terminal of the op amp as shown in the circuit of Fig. 4b. In this circuit, the input signal voltage is still zero but the presence of the offset voltage will cause the output voltage of the feedback amplifier to be non-zero. A routine calculation shows that the output voltage of this circuit is given by the expression

$$V_{\text{OUT}} = V_{\text{OS}} \left(1 + \frac{R_2}{R_1} \right) \quad (5)$$

By making the resistor ratio large, the offset voltage can be obtained from (5) by measuring the output voltage and then dividing by the term in parenthesis. A resistor ratio of 100 or even 1000 is useful for easily and accurately measuring the offset voltage.

2.5 Output Impedance, R_o (extra credit)

The output impedance of an operational amplifier is sufficiently low that in most applications one can justify assuming that the output impedance is zero. When feedback is applied the closed loop output impedance which can be related to the output impedance of the op amp becomes really small. As such, measurement of the output impedance is challenging.

Devise and apply an output measurements strategy for measuring the output impedance of the TL082 op amp.

In this measurement, remember that the maximum output current specification of the op amp must not be violated.

2.6 3dB Bandwidth (extra credit)

The 3dB bandwidth of an operational amplifier is often in the range of 10 rad/sec and the gain at this frequency is very large. Though conceptually straightforward, a direct measurement of the 3dB bandwidth is challenging. It is often calculated by measuring the dc gain and the GB of the op amp and taking the ratio

$$BW = p = GB/A_0. \quad (6)$$

But methods can be developed to measure the 3dB bandwidth directly.

Devise a method of measuring directly the BW of an op amp and use this method to measure the BW of the TL082. Compare with that calculated from (6) and that given in the datasheet.

3 Single-ended Feedback Amplifier

Many feedback applications do not require the use of a differential input operational amplifier. One of the simplest single-ended amplifiers is the push-pull amplifier of Fig. 1. Even though this amplifier does not have a particularly large open-loop gain, it does provide modest performance when used to build a feedback amplifier.

Use this amplifier to build and test a feedback amplifier with a dc gain of -2 using the architecture of Fig. 5.

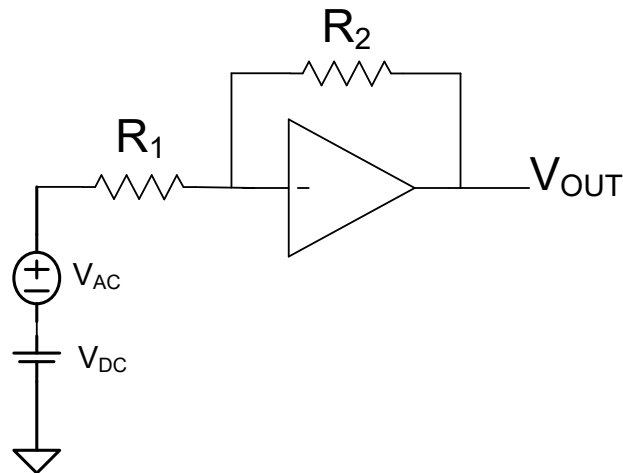

Fig. 5 Single-ended Op Amp in Feedback Configuration

Use rather large resistors when building this amplifier. A feedback resistor in the $1\text{M}\Omega$ range would be reasonable. It is important to set the bias voltage V_{DC} to be quite close to the quiescent output voltage you desire for this amplifier. The quiescent output voltage should be the same value you used in Sec 2.1 of this experiment for measuring the voltage gain of the amplifier. The same values you used for V_{DD} and V_{SS} should be used when measuring the gain should be used here as well.

4 Stability and Compensation

Although the issues of stability and compensation have not yet been addressed in the lecture part of this course, issues relating to stability and compensation will be investigated in the laboratory. It will be shown later that if a high-gain amplifier is designed and then feedback is applied, the higher-order poles of the amplifier often cause feedback amplifiers using the op amp to become unstable. An unstable circuit is one that will have a periodic or oscillatory output when no input signal is applied (e.g. $V_{IN}=0\text{V}$) or one that will have an output that will latch at some fixed voltage. Instability is a very undesirable characteristic of a feedback amplifier and makes circuits that are unstable almost useless as amplifiers. Considerable effort is expended in the design of an amplifier so that feedback circuits using the amplifier do not become unstable. Invariably

these efforts are focused on what is termed “compensation” in which attempts are made to control the relative positions of the low frequency poles and the high frequency poles of the amplifier. Instability can be thought of as an extreme case of under-damping of the feedback amplifier. The performance of an amplifier that is highly under-damped or even modestly under-damped is generally unacceptable as well even if no oscillation exists. An under-damped amplifier will exhibit overshoot and or ringing when a square wave or step input is applied. An under-damped feedback amplifier will also exhibit peaking in the frequency response of the amplifier.

With many op amps, the designer must make tradeoffs between the GB of the op amp, power dissipation, and capacitive load driving capability. For this reason, the data sheet of many op amps will specify a maximum capacitive load that can be applied. Even when applying the specified maximum capacitive load, feedback circuits using such operational amplifiers may become under-damped and thus exhibit a degradation in performance but invariable if the maximum load capacitance is exceeded by very much, the feedback amplifier will become oscillatory.

Consider a basic noninverting amplifier connected in the unity gain (buffer) configuration. This circuit is shown in Fig. 6.

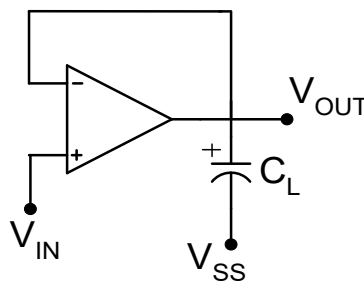

Fig. 6 Basic Buffer Amplifier

Note that the lower plate of the capacitor was intentionally connected to V_{SS} rather than to ground and that a polarity of the capacitor has been explicitly indicated. This is a practical way to guarantee that the load capacitance is correctly connected if it is an electrolytic capacitor.

Measure the step response or the square wave response of this circuit using the TL082 op amp with the following capacitive load values:

47 nF 100 nF 1 μ F 10 μ F 100 μ F

For which capacitor values does the response become under-damped? Does the response become oscillatory for large capacitive loads? If oscillatory, at what frequency does the output oscillate? When oscillatory, verify that the oscillation is sustained even when the input voltage is 0V. How do these capacitive loads relate to the limitations established by the manufacturer?

Note: The datasheet for the TL082 is lacking details about how large of a capacitive load can be driven but Fig. 6-27 in the datasheet posted with this experiment should give some insight. The amplifier will become unstable when the phase margin drops to 0° .